











# Assembly Instructions

## MODEL NO. SOV-V-3CT-460-120

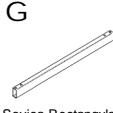
REV-1

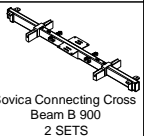
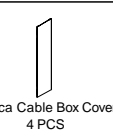
**HARDWARE LIST**

<b>A</b>	<b>B</b>	<b>C</b>	<b>D</b>	<b>E</b>	<b>F</b>	<b>G</b>	<b>H</b>
							
Sovica Curve End Leg 2 SETS	Sovica Rectangular Beam Connector A 4 PCS	Sovica Top Support A 8 PCS	Set Screw M8 x 20 mm 8 PCS	Pan Head Self Tapping Screw #10 x 3/4" 8 PCS	PHM Screw M6 x 16 24 PCS	Sovica Rectangular Beam 6 SET	Sovica Access Profile Bar Bracket-2 PCS JCBC Screw M6 X 10 mm-4 PCS
<b>I</b>	<b>J</b>	<b>K</b>	<b>L</b>				
							
Sovica Connecting Cross Beam B 900 2 SETS	Sovica Cable Box Cover 4 PCS	PHM Screw M6 x 16 16 PCS	4 Hole Bracket 80 x 60 x 3 mm-4 PCS PHM Screw M6 x 16-16 PCS				
*Hardware from SOV-CB-500							

**TOOLS REQUIRED**

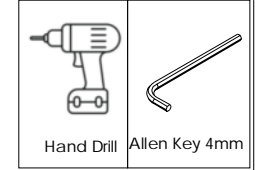

**STEP 1**

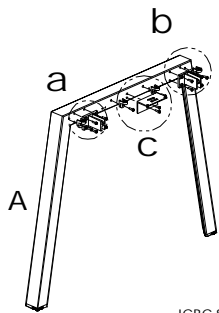

JCBC Screw M6x35

**STEP 2**

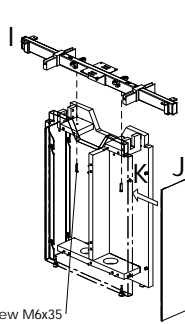

**STEP 3**

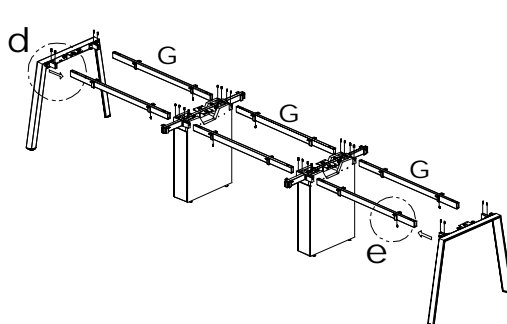

**STEP 4**

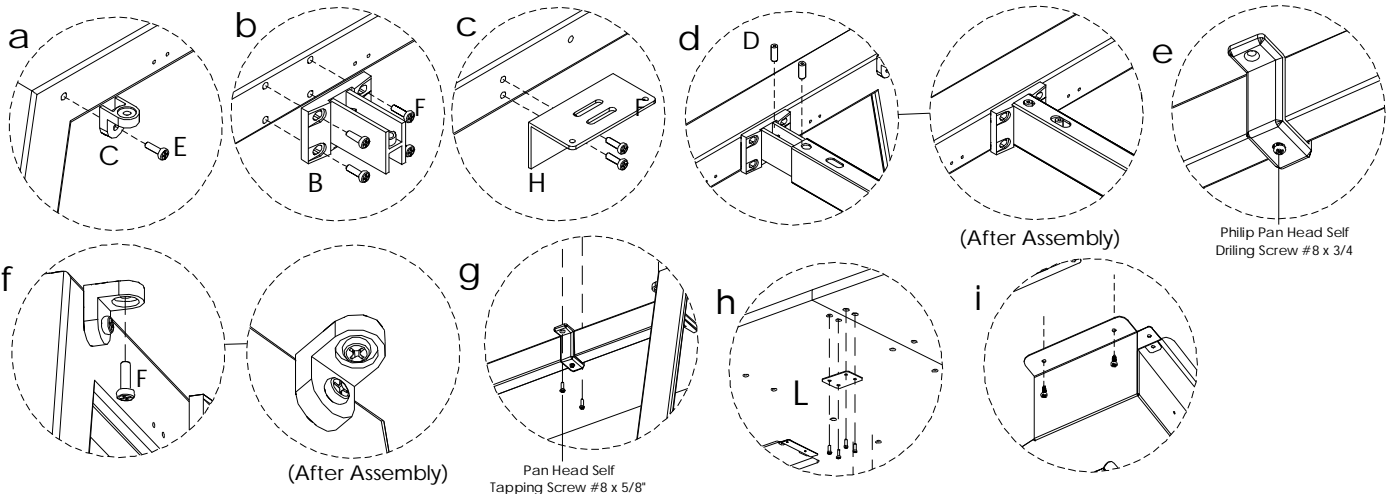
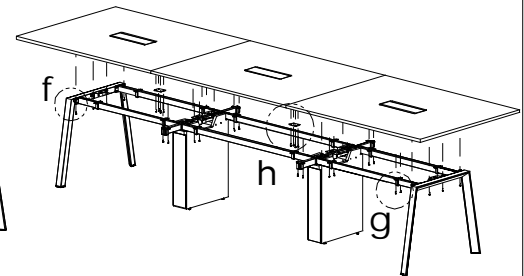

(After Assembly)

Philp Pan Head Self Drilling Screw #8 x 3/4

Pan Head Self Tapping Screw #8 x 5/8"

**STEP 4**

**COMPLETED ASSEMBLY**

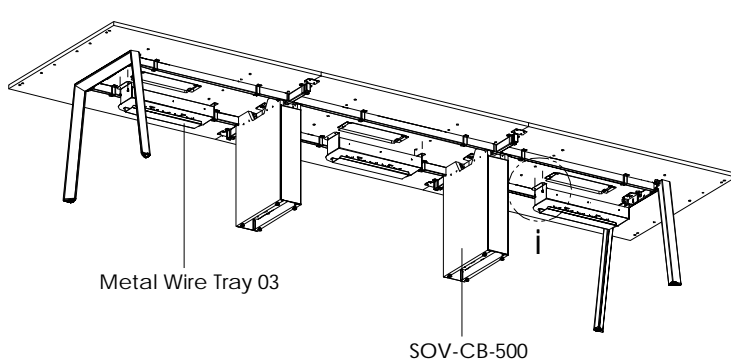

Metal Wire Tray 03

SOV-CB-500

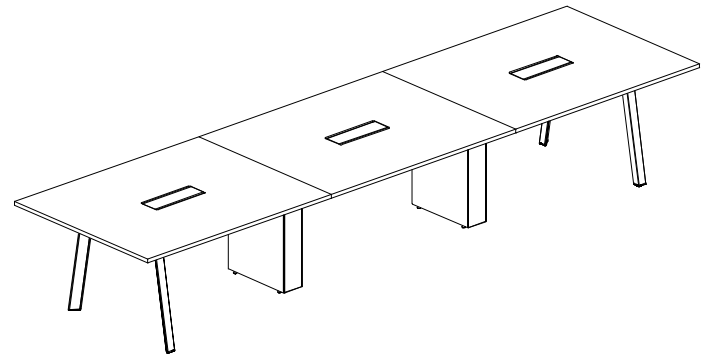

**IMPORTANT NOTE:**

- 1) Place all laminated parts on a clean and smooth surface such as a rug or carpet to avoid the parts from being scratched.
- 2) Check to be sure that you have all parts and hardware.
- 3) Remove all wrapping materials, including staples & packing straps before you start to assemble.
- 4) Keep all hardware parts out of reach of children.
- 5) If the product is not working properly, is missing a part, is damaged, or if you have any questions, please call customer service hotline before returning. To smoothen the process, kindly provide the invoice number, SO number and photo of damaged part or missing pieces to the handler.
- 6) Customer Service Hotline : +6 03 - 3392 6888. For further assembly instructions, please email us at [info@versalink.com](mailto:info@versalink.com)

