









# Assembly Instructions

## MODEL NO. SOV-C-CL2-DE120120SL SOV-C-CL2-DE160120SL

REV-1

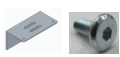
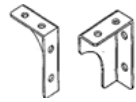
**HARDWARE LIST**

|  |   |   |   |   |   |   |  |
|--|---|---|---|---|---|---|--|
| <p><b>A</b></p>  <p>Sovica Curve End Leg<br/>1 SET</p>               | <p><b>B</b></p>  <p>Sovica Rectangular Beam Connector A<br/>4 PCS</p>                                    | <p><b>C</b></p>  <p>Sovica Top Support A<br/>8 PCS</p> | <p><b>D</b></p>  <p>Set Screw M8 x 20 mm<br/>8 PCS</p>     | <p><b>E</b></p>  <p>Pan Head Self Tapping Screw #10 x 3/4"<br/>8 PCS</p> | <p><b>F</b></p>  <p>PHM Screw M6 x 16<br/>24 PCS</p> | <p><b>G</b></p>  <p>Sovica Rectangular Beam<br/>2 SET</p> | <p><b>H</b></p>  <p>Sovica Access Profile Bar Bracket-2 PCS<br/>JCBC Screw M6 X 10 mm-4 PCS</p> |
| <p><b>I</b></p>  <p>Screen Panel Metal Bracket - Set A<br/>1 SET</p> | <p><b>J</b></p>  <p>1/4 FLAT Washer - 2 PCS<br/>Philip Pan Head Self Drilling Screw #8 x 3/4 - 2 PCS</p> |   | <p><b>K</b></p>  <p>Sovica M Shape Curve Leg<br/>1 SET</p> |   |   |   |  |

**TOOLS REQUIRED**

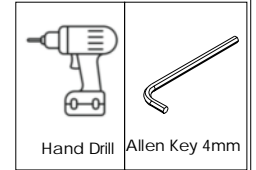

\*Hardware from Screen Panel

\*Hardware from Vertical Cable Channel 05

**STEP 2**

**STEP 3**

**STEP 1**

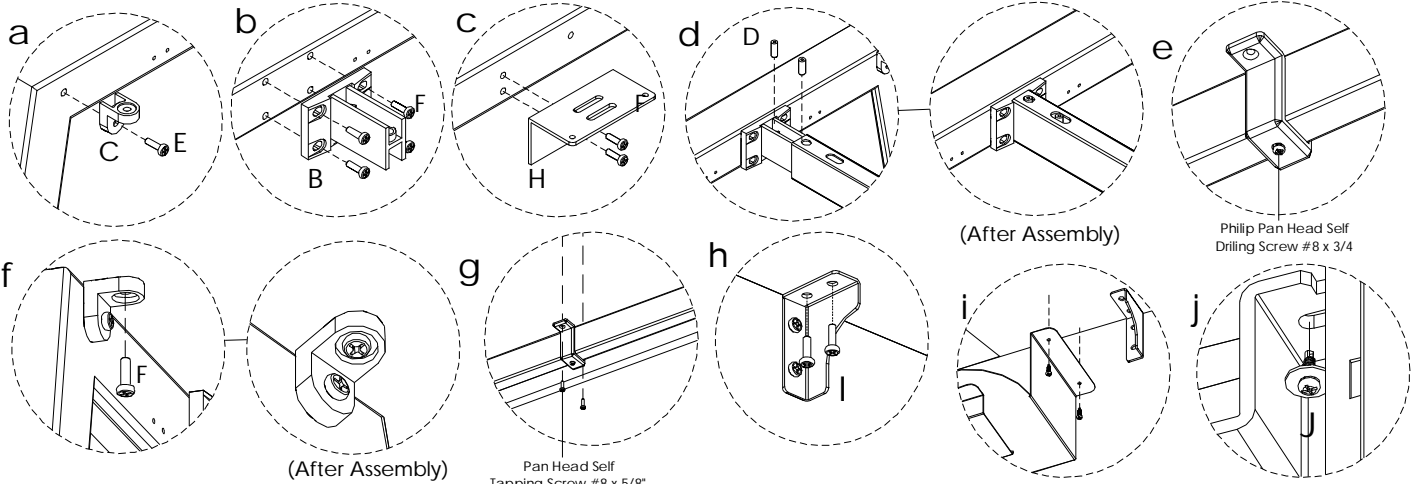
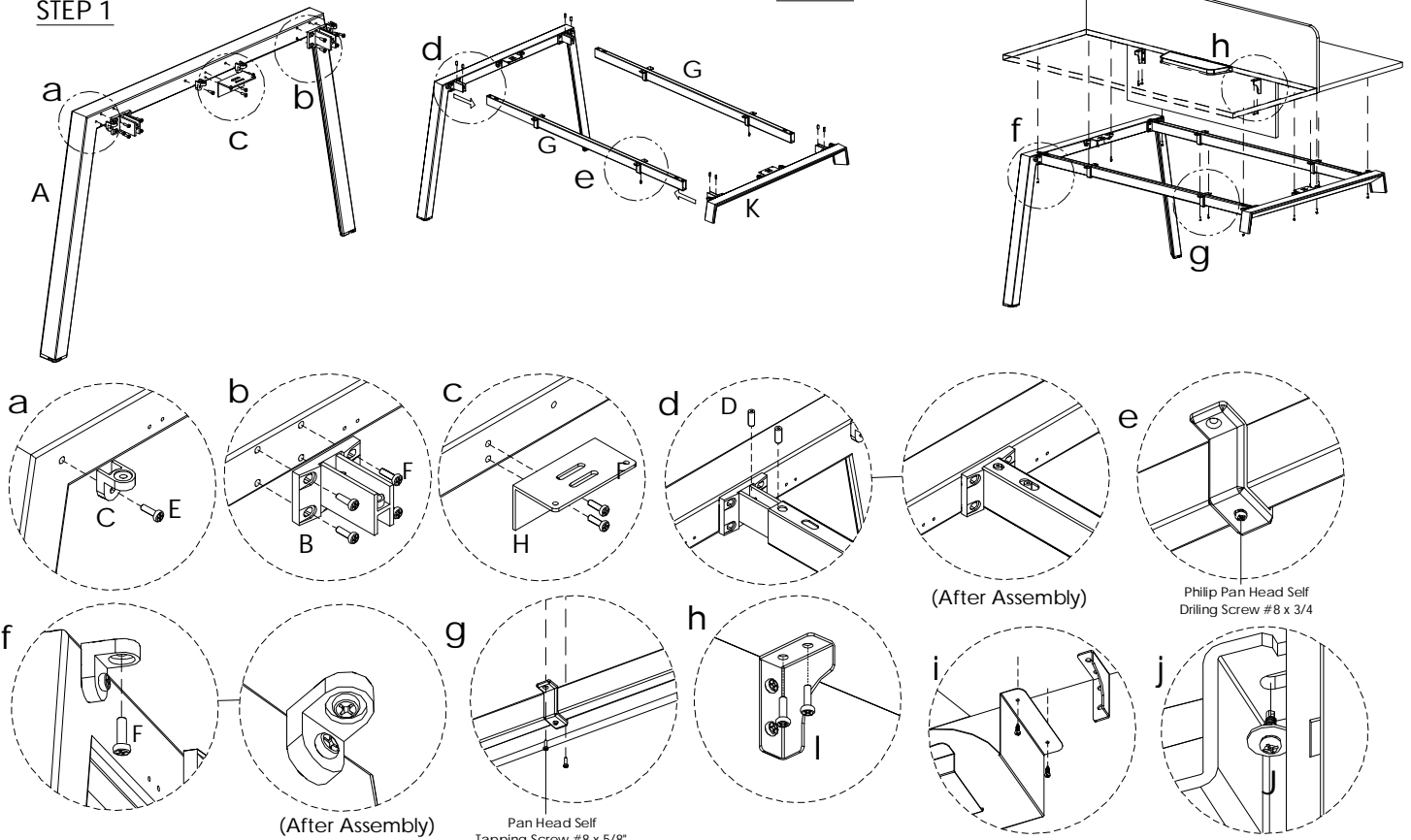

**STEP 4**

**COMPLETED ASSEMBLY**

Screen Panel

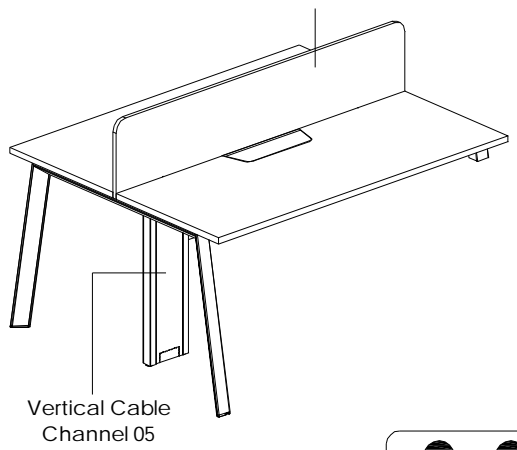
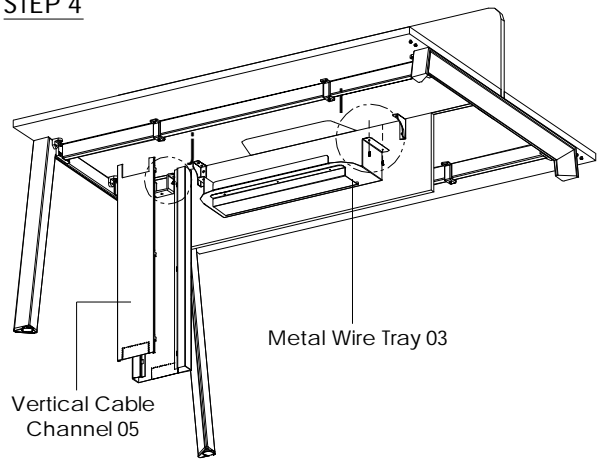

**IMPORTANT NOTE:**

- 1) Place all laminated parts on a clean and smooth surface such as a rug or carpet to avoid the parts from being scratched.
- 2) Check to be sure that you have all parts and hardware.
- 3) Remove all wrapping materials, including staples & packing straps before you start to assemble.
- 4) Keep all hardware parts out of reach of children.
- 5) If the product is not working properly, is missing a part, is damaged, or if you have any questions, please call customer service hotline before returning. To smoothen the process, kindly provide the invoice number, SO number and photo of damaged part or missing pieces to the handler.
- 6) Customer Service Hotline : +6 03 - 3392 6888. For further assembly instructions, please email us at [info@versalink.com](mailto:info@versalink.com)

