







Assembly Instructions

MODEL NO. SOV-EC-SR090-60DL
SOV-EC-SR100-60DL



REV-1

HARDWARE LIST

A		B		C		D		E		F	
	Sovica Curve End Leg 1 SET		Sovica Rectangular Beam Connector A 1 PCS		Sovica Top Support A 2 PCS		Set Screw M8 x 20 mm 2 PCS		Pan Head Self Tapping Screw #10 x 3/4" 2 PCS		PHM Screw M6 x 16 6 PCS

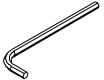
TOOLS REQUIRED

	
Hand Drill	Allen Key 4mm

	
4 Hole Bracket 80 x 60 x 3 mm -2 PCS PHM Screw M6 x 16 -4 PCS Pan Head Self Tapping Screw #8 x 5/8" -4 PCS	Beam Support 5025 -2 PCS Philip Pan Head Self Drilling Screw #8 x 3/4 -2 PCS Pan Head Self Tapping Screw #8 x 5/8" -4 PCS

STEP 1

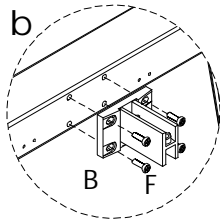
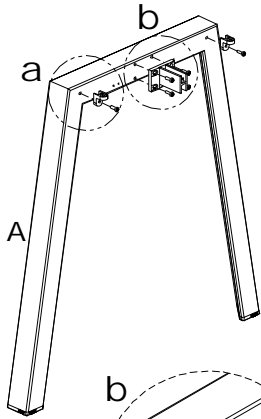

STEP 2

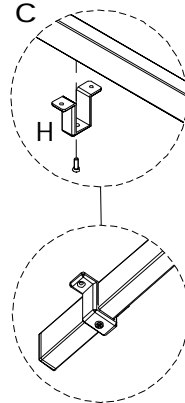
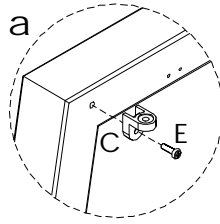
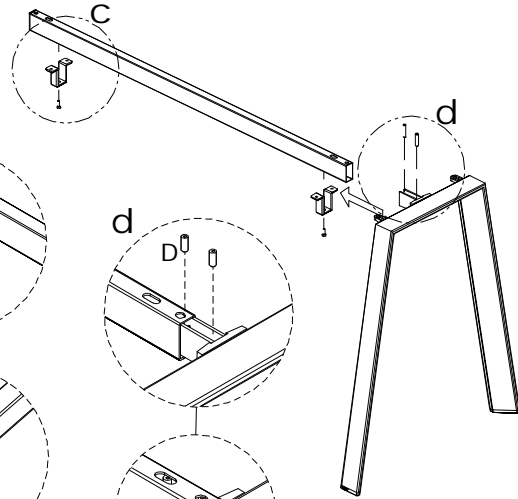

(After Assembly)

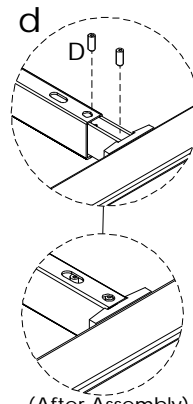

(After Assembly)

STEP 3

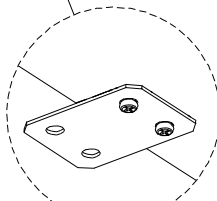
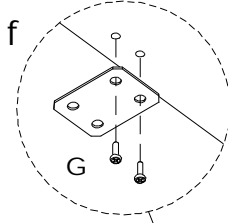
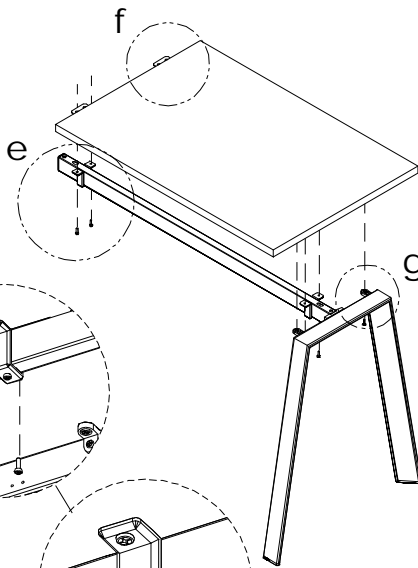

(After Assembly)

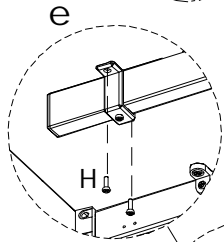

(After Assembly)

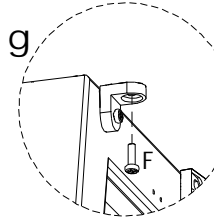

(After Assembly)

COMPLETED ASSEMBLY

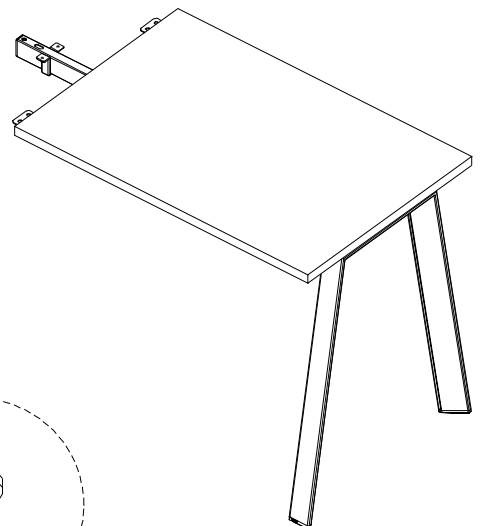

IMPORTANT NOTE:

- 1) Place all laminated parts on a clean and smooth surface such as a rug or carpet to avoid the parts from being scratched.
- 2) Check to be sure that you have all parts and hardware.
- 3) Remove all wrapping materials, including staples & packing straps before you start to assemble.
- 4) Keep all hardware parts out of reach of children.
- 5) If the product is not working properly, is missing a part, is damaged, or if you have any questions, please call customer service hotline before returning. To smoothen the process, kindly provide the invoice number, SO number and photo of damaged part or missing pieces to the handler.
- 6) Customer Service Hotline : +6 03 - 3392 6888. For further assembly instructions, please email us at info@versalink.com

