







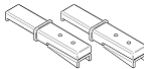

Assembly Instructions

MODEL NO. PTZ-EC-MDB180-80L/R
PTZ-EC-MDB210-80L/R

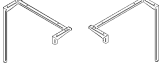
REV-1
PAGE-1

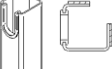
HARDWARE LIST

TOOLS REQUIRED

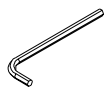
A	B	C	D	E	F	G	
							
platz+ Fitting 2-01 2 SETS	platz+ End Metal Leg 800 1 PC	Platz Single End Metal Leg 800 - Left / Right 1 PC	Rectangular Beam B 2 PCS	Platz Magnetic Cable Management - 640 2 PCS	PHM Screw M6 x 20 2 PCS	Modesty Bracket 02-2 PCS PHM Screw M6 x 16-8 PCS	Hand Drill
							 Allen Key 4mm

STEP 1

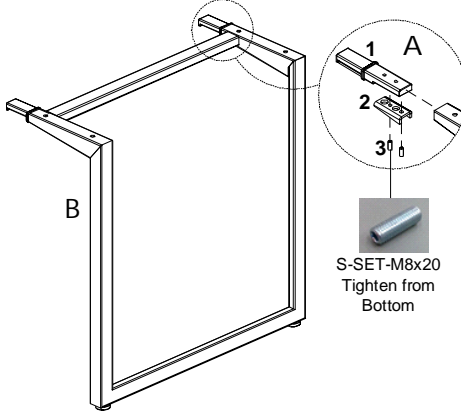

STEP 2

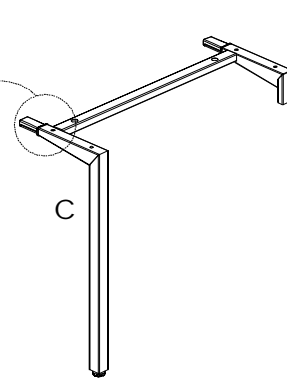

STEP 3

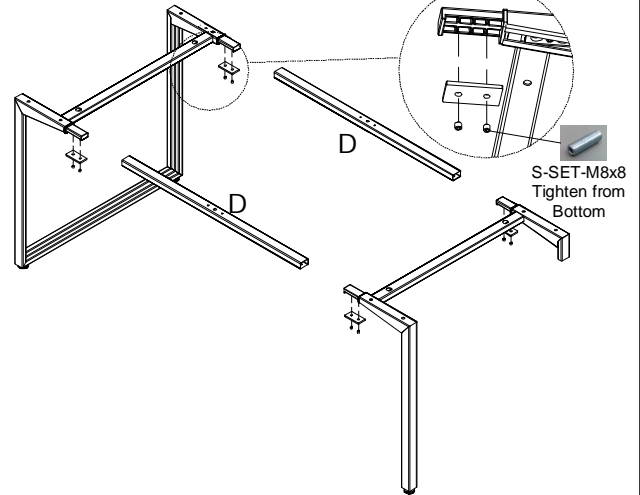

STEP 4

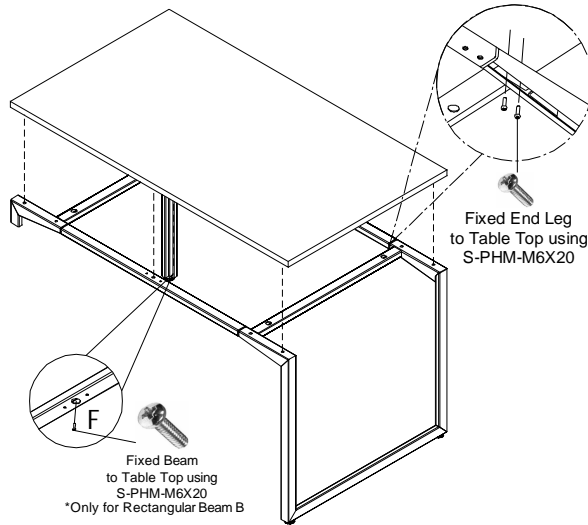

STEP 5

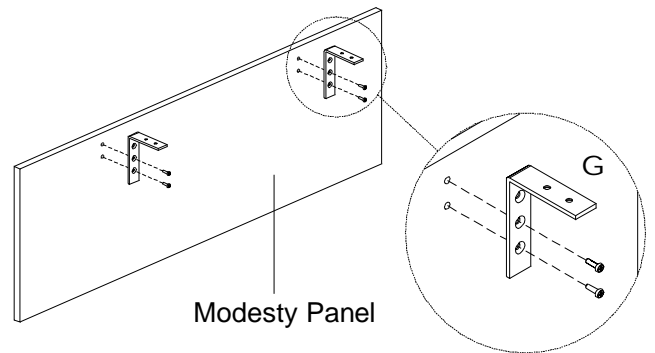

STEP 6

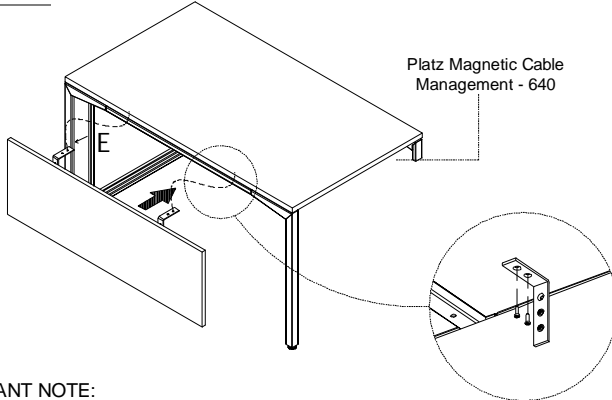

STEP 7

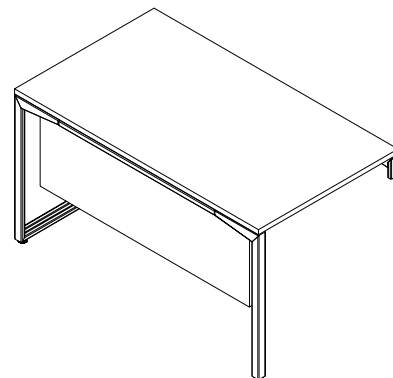

IMPORTANT NOTE:



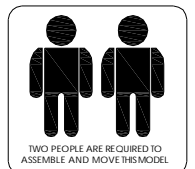









- 1) Place all laminated parts on a clean and smooth surface such as a rug or carpet to avoid the parts from being scratched.
- 2) Check to be sure that you have all parts and hardware.
- 3) Remove all wrapping materials, including staples & packing straps before you start to assemble.
- 4) Keep all hardware parts out of reach of children.
- 5) If the product is not working properly, is missing a part, is damaged, or if you have any questions, please call customer service hotline before returning. To smoothen the process, kindly provide the invoice number, SO number and photo of damaged part or missing pieces to the handler.
- 6) Customer Service Hotline : +6 03 - 3392 6888. For further assembly instructions, please email us at info@versalink.com



Assembly Instructions

MODEL NO. PTZ-EC-MDB180-80L/R
PTZ-EC-MDB210-80L/R

HARDWARE LIST

H		I		J		K		L		M		N		O		P		Q		R		S	
	MF-SBOLT-JT-10259 15 PCS		MF-CAM-JJ-10107 15 PCS		DECO-STC-20-COM 15 PCS		DW-WD-M8X40 15 PCS		S-CB4X16 20 PCS		ACC-ADJ-LVL-N2880/ ACC-ADJ-LVL-N2881/ ACC-LVL-N2880-CAP 5 PCS		STUD-COLLAR-010 6 PCS		ACC-RIM-LOCK-648S BK-L-HUWIL-34X13X10 1 SET		PTZ-HD-SP150 1 PC		S-JCBC-M6X30 8 PCS		S-JCBC-M6X40 1 PC		GRO-PLC-RCT8050 2 PCS

STEP 8

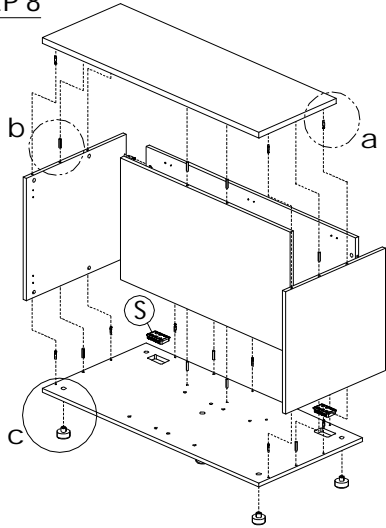

STEP 9

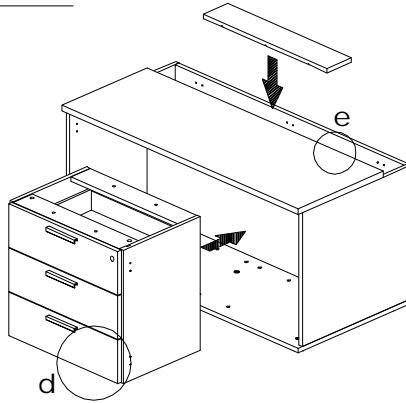

STEP 10

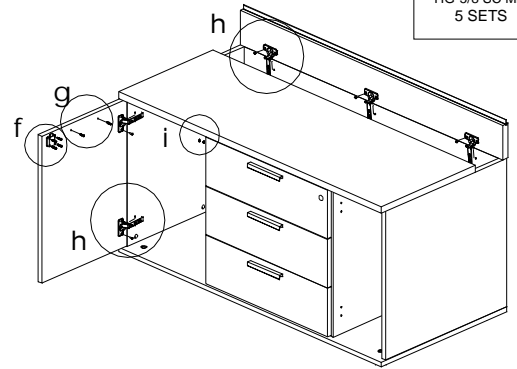

COMPLETED ASSEMBLY

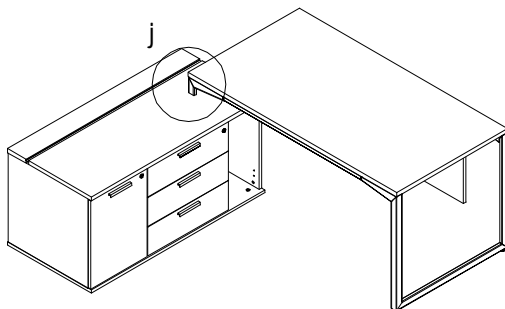

LEFT HAND SIDE VIEW

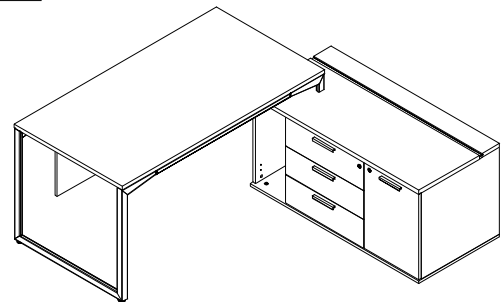

RIGHT HAND SIDE VIEW

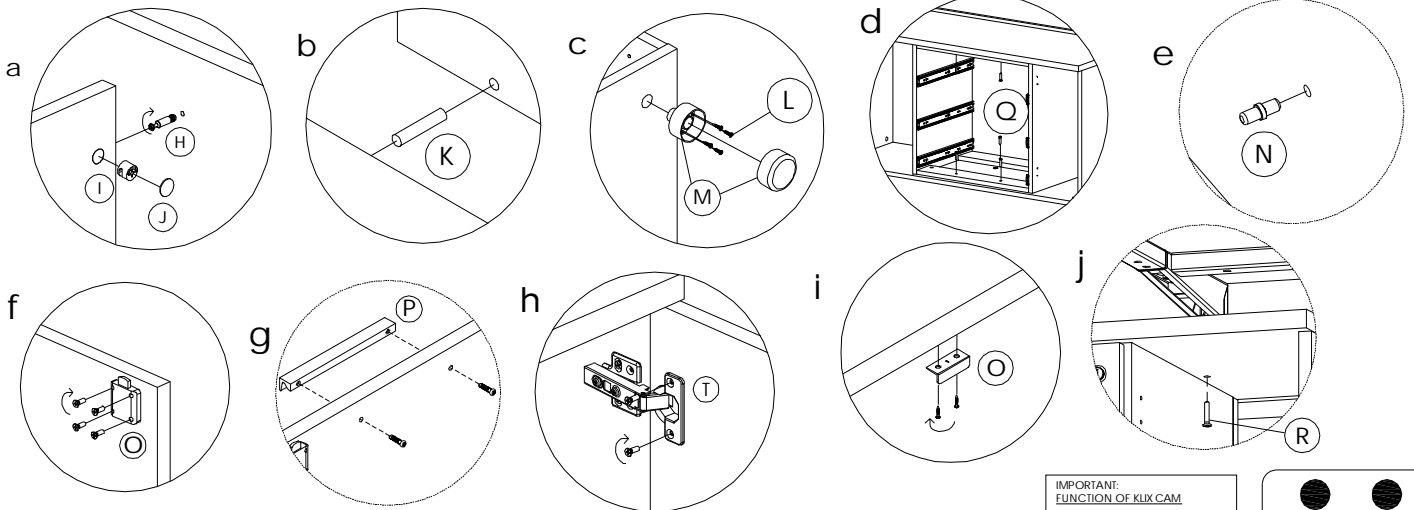

IMPORTANT NOTE:

- 1) Place all laminated parts on a clean and smooth surface such as a rug or carpet to avoid the parts from being scratched.
- 2) Check to be sure that you have all parts and hardware.
- 3) Remove all wrapping materials, including staples & packing straps before you start to assemble.
- 4) Keep all hardware parts out of reach of children.
- 5) If the product is not working properly, is missing a part, is damaged, or if you have any questions, please call customer service hotline before returning. To smoothen the process, kindly provide the invoice number, SO number and photo of damaged part or missing pieces to the handler.
- 6) Customer Service Hotline : +6 03 - 3392 6888. For further assembly instructions, please email us at info@versalink.com

