







# Assembly Instructions CORIUM END LEG

**HARDWARE LIST**

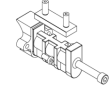
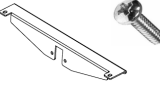
**TOOLS REQUIRED**

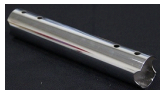
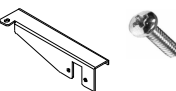
<p><b>A</b></p>  <p>Corium Cross Beam Connector</p>	<p><b>B</b></p>  <p>Corium Cross Beam Connector Cap</p>	<p><b>C</b></p>  <p>Corium Rectangular Beam Connector</p>	<p><b>D</b></p>  <p>Corium Worktop Holder A</p>	<p><b>E</b></p>  <p>Corium Metal Leg 116</p>	<p><b>F</b></p>  <p>Corium Side Cross Beam</p>	<p><b>G</b></p>  <p>Corium Worktop Holder B</p>	 <p>Hand Drill</p>	 <p>Allen Key 4mm</p>
---	--	--	--	---	---	--	---	--

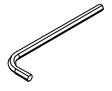
**STEP 1**

Assembly Part A,B,C

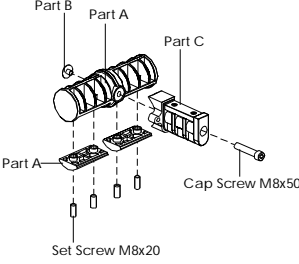

Assembly Part E

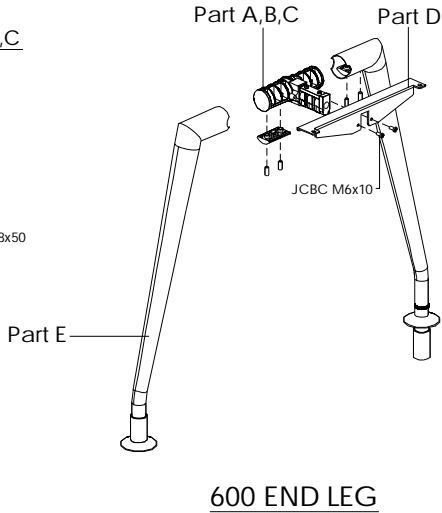
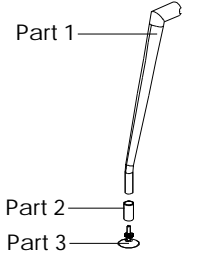

Remarks:  
Assembly Part A,B,C,D,E & F become a frame. Use allen key to fix the set screw M8 to the profile as details shown.

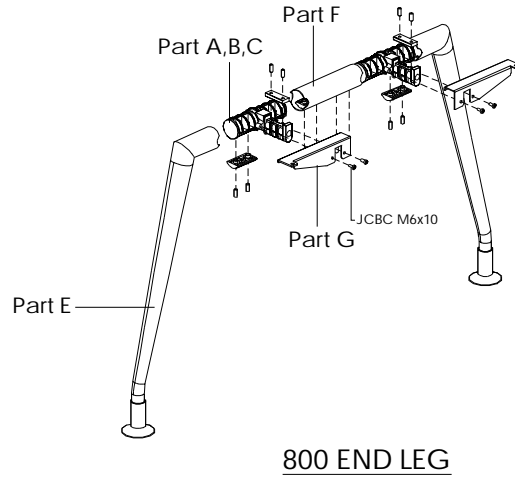

Remarks:  
Assembly Part A,B,C,E,F & G become a frame. Use allen key to fix the set screw M8 to the profile as details shown.

COMPLETED ASSEMBLY

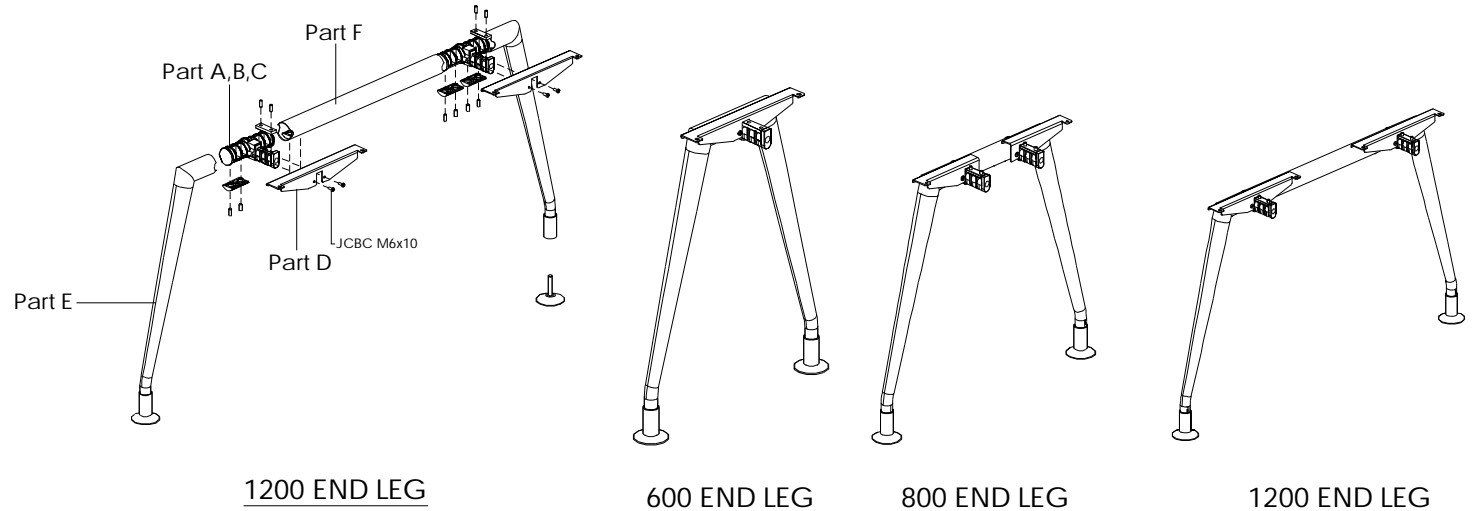

Remarks:  
Assembly Part A,B,C,D,E & F become a frame. Use allen key to fix the set screw M8 to the profile as details shown.

**IMPORTANT NOTE:**

- 1) Place all laminated parts on a clean and smooth surface such as a rug or carpet to avoid the parts from being scratched.
- 2) Check to be sure that you have all parts and hardware.
- 3) Remove all wrapping materials, including staples & packing straps before you start to assemble.
- 4) Keep all hardware parts out of reach of children.
- 5) If the product is not working properly, is missing a part, is damaged, or if you have any questions, please call customer service hotline before returning. To smoothen the process, kindly provide the invoice number, SO number and photo of damaged part or missing pieces to the handler.
- 6) Customer Service Hotline : +6 03 - 3392 6888. For further assembly instructions, please email us at [info@versalink.com](mailto:info@versalink.com)

