

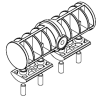

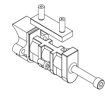



Assembly Instructions CORIUM CONNECTING LEG

HARDWARE LIST

A	B	C	D	E
				
Corium Cross Beam Connector	Corium Rectangular Beam Connector	Corium Worktop Holder A	Corium Metal Leg 116	Corium Side Cross Beam

TOOLS REQUIRED

	
Hand Drill	Allen Key 4mm

STEP 1

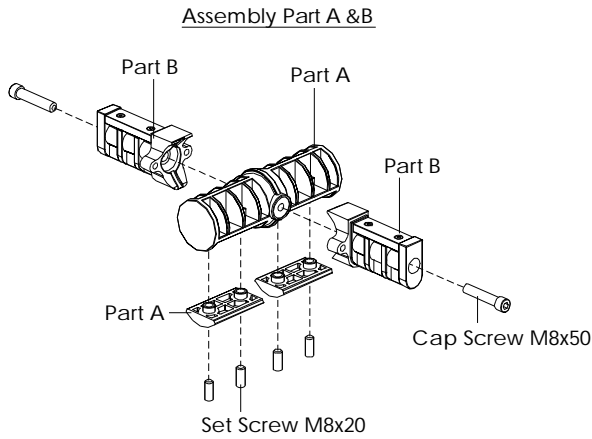

STEP 2

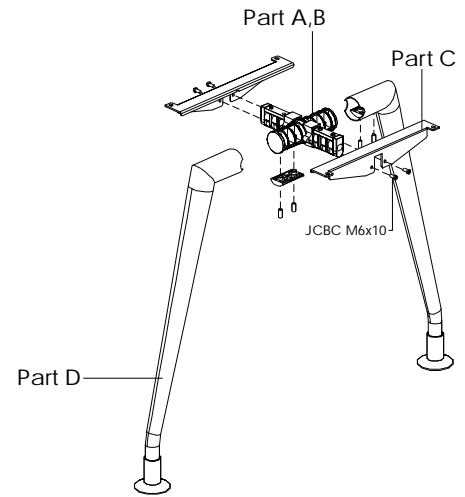
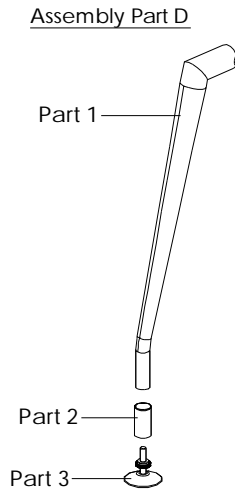

600 CONNECTING LEG

Remarks:

Assembly Part A,B,C & D become a frame. Use allen key to fix the set screw M8 to the profile as details shown.

COMPLETED ASSEMBLY

STEP 3

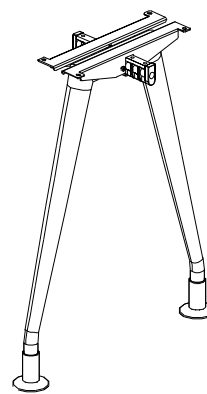
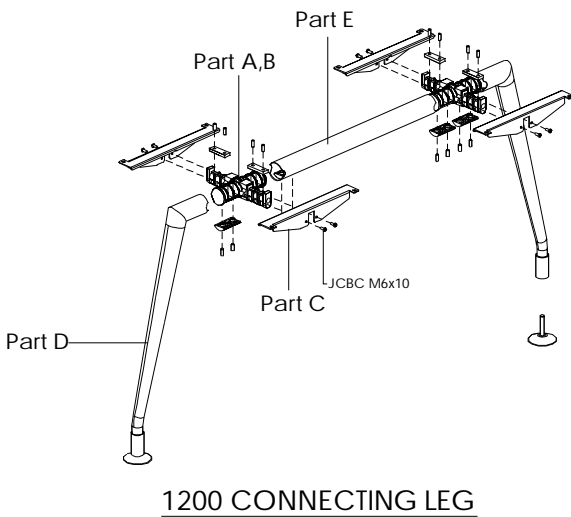

600 CONNECTING LEG

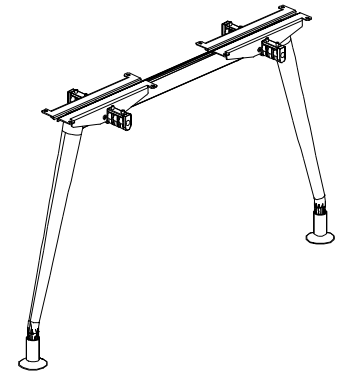

1200 CONNECTING LEG

Remarks:

Assembly Part A,B,C,D & E become a frame. Use allen key to fix the set screw M8 to the profile as details shown.

IMPORTANT NOTE:

- 1) Place all laminated parts on a clean and smooth surface such as a rug or carpet to avoid the parts from being scratched.
- 2) Check to be sure that you have all parts and hardware.
- 3) Remove all wrapping materials, including staples & packing straps before you start to assemble.
- 4) Keep all hardware parts out of reach of children.
- 5) If the product is not working properly, is missing a part, is damaged, or if you have any questions, please call customer service hotline before returning. To smoothen the process, kindly provide the invoice number, SO number and photo of damaged part or missing pieces to the handler.
- 6) Customer Service Hotline : +6 03 - 3392 6888. For further assembly instructions, please email us at info@versalink.com

