

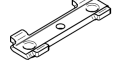



Assembly Instructions

MODEL NO. LEX-EC-CL6-D120T
LEX-EC-CL6-D150T

REV-1

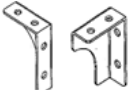
HARDWARE LIST

<p>A</p>  <p>Set Screw M8 x 45 24 PCS</p>	<p>B</p>  <p>Solo Rectangular Beam Reinforcement A 12 PCS</p>	<p>C</p>  <p>PHM Screw M6 x 16 48 PCS</p>	<p>D</p>  <p>Screen Panel Metal Bracket - Set A 3 SETS</p>
<p>E</p>  <p>1/4 FLAT Washer - 2 PCS Philip Pan Head Self Drilling Screw #8 x 3/4 - 2 PCS</p>			
<p>*Hardware from Lex End Cross Beam & Lex Connecting Cross Beam</p>		<p>*Hardware from Screen Panel</p>	
<p>*Hardware from Vertical Cable Channel 03</p>			

TOOLS REQUIRED

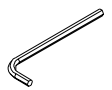
 <p>Hand Drill</p>	 <p>Allen Key 4mm</p>
---	--

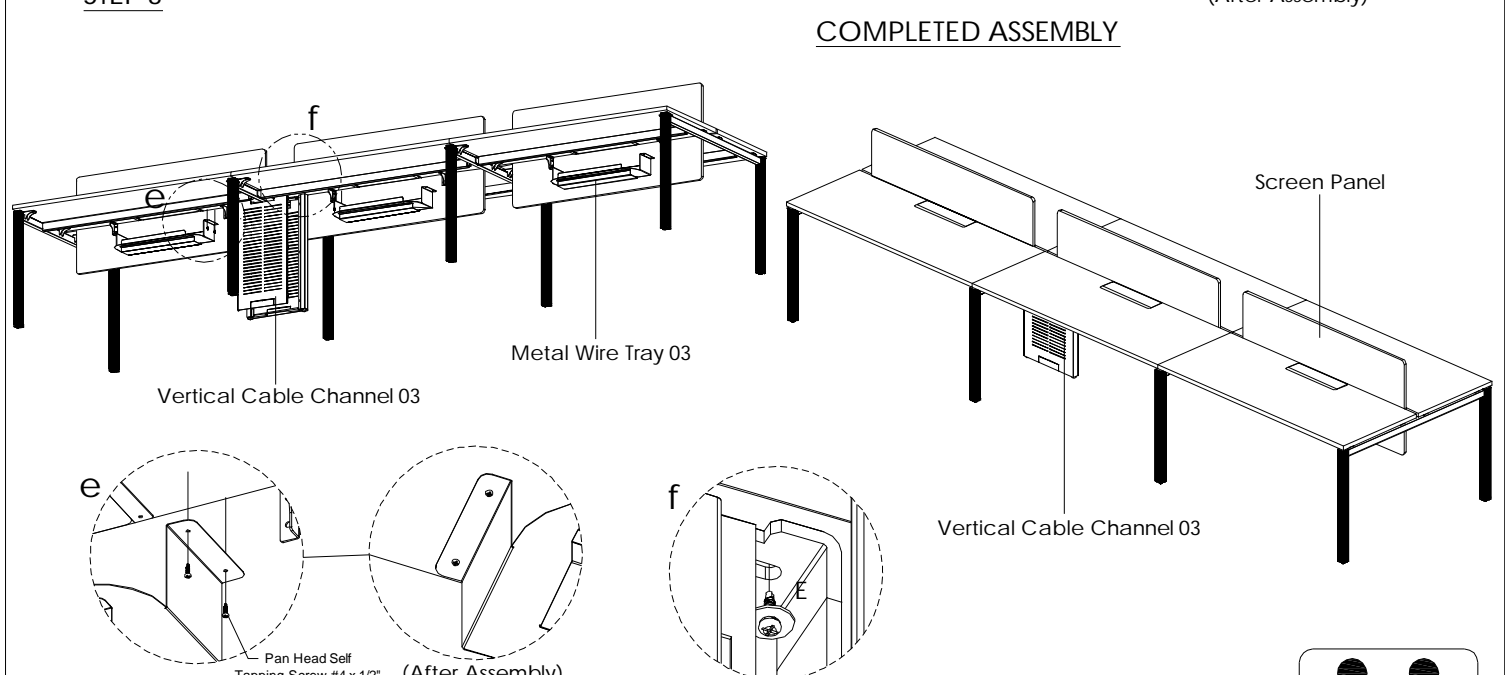
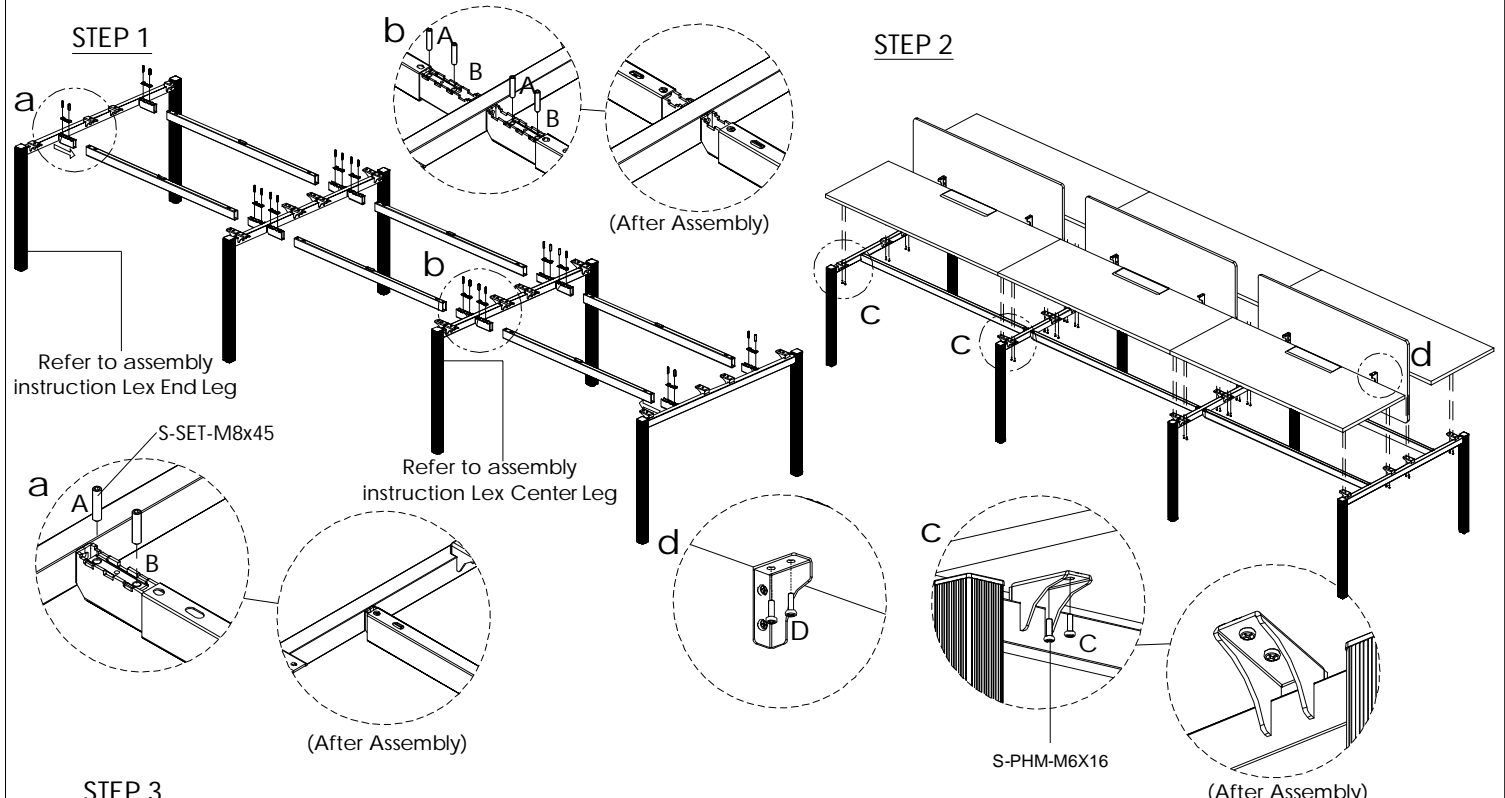

IMPORTANT NOTE:

- 1) Place all laminated parts on a clean and smooth surface such as a rug or carpet to avoid the parts from being scratched.
- 2) Check to be sure that you have all parts and hardware.
- 3) Remove all wrapping materials, including staples & packing straps before you start to assemble.
- 4) Keep all hardware parts out of reach of children.
- 5) If the product is not working properly, is missing a part, is damaged, or if you have any questions, please call customer service hotline before returning. To smoothen the process, kindly provide the invoice number, SO number and photo of damaged part or missing pieces to the handler.
- 6) Customer Service Hotline : +6 03 - 3392 6888. For further assembly instructions, please email us at info@versalink.com

